

FEATURES

MFCH

- For both water washed or dry cleaned shirts, anoraks or jackets
- **Without boiler:** to be connected to a central steam supply.
- Can be installed with a steam generator GV-24 - 22 KW
- Two sleeve stretchers with double independent traction.
- Front heated and reclining panel.
- Automatic carriage with photocell for the stretching of side and back part.
- Powerful 3 HP fan.
- Button placket part of the dummy with suction.
- Electronic card featuring nine programs for an automatic working cycle.
- Pneumatically operated air flow regulation device.
- Manually adjustable shoulder width.
- Pneumatically adjustable height of dummy.
- Air working pressure: 5-6 bar.
- Air consumption: 20 NI/min.
- Voltage 400V III+N / 230V III 50-60 Hz



OPTIONS

- Steam iron assembly

TECHNICAL DATA	UNIT.	MFCH
GENERAL DETAILS		
Board dimensions	mm	-
Boiler	-	No
Boiler capacity	l	-
Compressor	-	-
Group of Iron	-	Opt.
Steam gun	-	-
Polished upper buck	-	-
POWER		
Vacuum Motor	HP	-
Pump Motor	HP	-
Compressor motor (Mod. with option)	-	-
Boiler Heater (Mod. with option)	-	-
Fan motor	HP	3
CONNECTIONS		
Ø Water inlet	BSP	-
Ø Boiler exhaust (mod. with boiler)	BSP	-
Ø Steam inlet	BSP	1/2"
Ø Condensate outlet	BSP	1/2"
Steam pressure	BAR	4-8
Steam Consumption	Kg/h	20-30
Ø Air inlet	BSP	1/4"
Ø Air outlet	mm	1/4"
Air pressure	BAR	6
Air Consumption	NI/min	20
DIMENSIONS / PACKING DIMENSIONS		
Net width / Gross width	mm	1.900 / 1.940
Net depth / Gross depth	mm	1.600 / 1.190
Net height / Gross height	mm	1.850 / 1.850
Net weight / Gross weight	kg	189 / 276
Volume	m ³	5,62 / 4,27
OTHERS		
Voltage	Hz	400V III 50/60
Sound level	dB	70

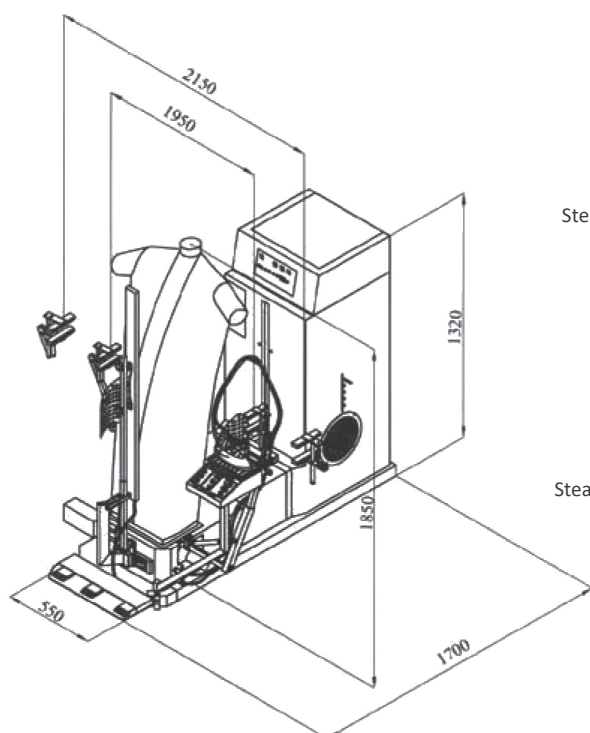

Compressed air 1/4": Advisable pressure min. 4 Bar - max. 7 Bar

