

# R2D25/140 - 200 GOLD WALL IRONERS Ø 250 mm



## BM ELECTRONIC PROGRAMMER

Simple and user friendly with an AUTO mode: automatic management of ironing speed according to the selected temperature.

Digital speed and temperature display



## FEATURES

Large roll contact area with the linen

Operation mode identical to a flatwork ironer: no roll lifting, more ergonomic

Models equipped as standard with Nomex belts, suction and variable speed inverter: more productivity

Adjustable speed and temperature



## ROBUSTNESS

Nomex coating: resistant to high temperatures

Panels in grey skinplate and stainless steel

Wooden feeding board

New kinematics, better reliability

Industrial components, more durable



## EFFICIENCY

Acoustic comfort : <55 dB

Minimum space requirement: space saving, suitable for small spaces

Ideal for processing small quantity of flat linen in facilities like restaurants, guest rooms, hostels...



## MAINTENANCE

Easy installation : requires only an electrical connection

Easy access on both sides for maintenance

Quick and easy dismantling of bearings



## OTHERS

Front feeding and return

Roll ø 180 mm

Working widths: 1.000 and 1.200 mm

Electric heating

CE certification



## OPTIONS

- Marine voltage 440V III 60 Hz without N
- 230V III+T 50-60 Hz

TECHNICAL DATA	UNIT.	R2D25/140 GOLD	R2D25/200 GOLD
<b>GENERAL DATA</b>			
Theoretical production*	Kg/h	40	50
Ø Roll	mm	250	250
Working width	mm	1.400	2.000
Ironing speed	mt/min	1,5 - 6	1,5 - 6
Electronic programmer	-	Yes	Yes
Bed lifting (manual by pedal)	-	None	None
<b>POWER</b>			
Heating power	Kw	7	12
Roll motor power	Kw	0,18	0,18
Fan motor power	Kw	0,12	0,12
Total electric power	Kw	7,3	12,3
<b>CONNECTIONS</b>		<b>ELECTRIC</b>	<b>ELECTRIC</b>
Tension 230V - III + T	N° x mm <sup>2</sup> /A	4 x 6 / 20A	3 x 10 / 40A
Tension 400V - III + N + T	N° x mm <sup>2</sup> /A	5 x 4 / 16A	5 x 4 / 20A
<b>OVERALL DIMENSIONS/ PACKING DIMENSIONS</b>			
Net width / Gross width	mm	1.923 / 1.890	2.523 / 2.490
Net depth / Gross depth	mm	484 / 540	484 / 540
Net height / Gross height	mm	985 / 1.130	985 / 1.130
Net weight / Gross weight	Kg	154 / 174	184 / 204
Net volume / Gross volume	m <sup>3</sup>	0,92 / 1,15	1,20 / 1,52
<b>OTHERS</b>			
Noise Level	dB	60	60

\*20-25% Theoretical production

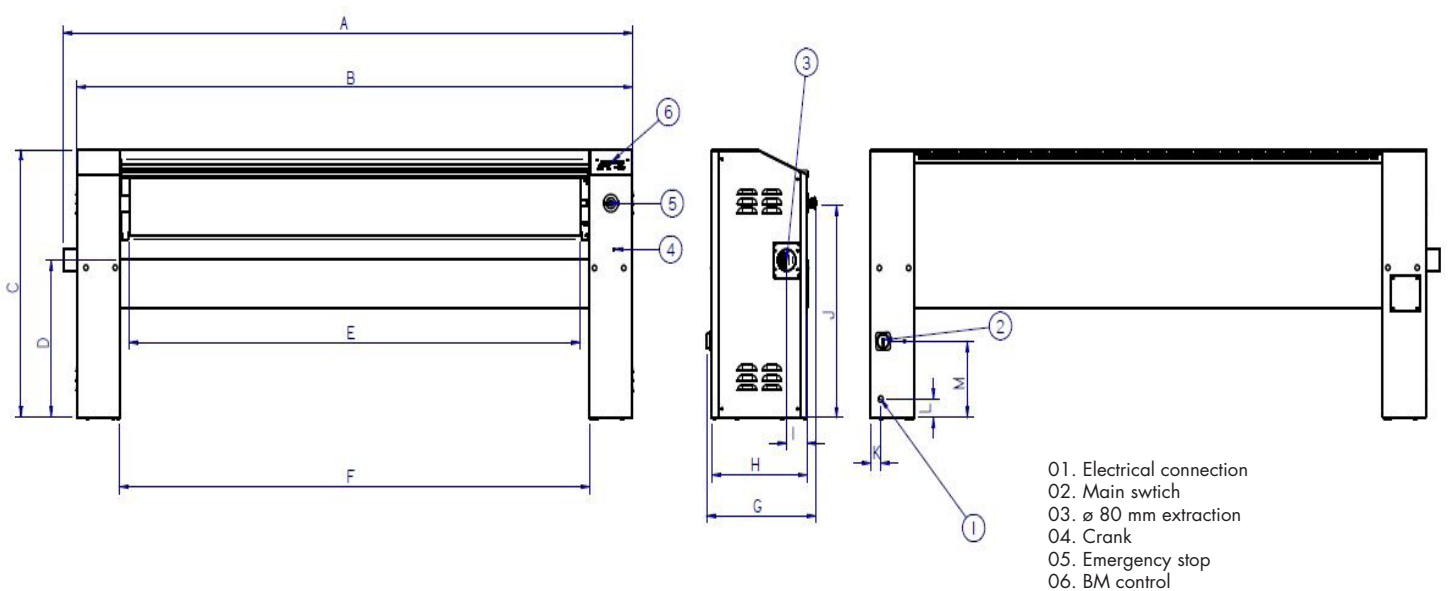

	A	B	C	D	E	F	G	H	I	J	K	L	M
R2D25/140 GOLD	1.923	1.862	985	610	1.400	1.480	484	423	91	791	45	75	287
R2D25/200 GOLD	2.523	2.462	985	610	2.000	2.080	484	423	91	791	45	75	287

